

CIRCULAR DUCT TYPE FANS

ENERGY
EFFICIENT
LONG LIFE



PRODUCT FEATURES

- Metal gövde Metal casing
- Uzun ömürlü rulmanlar Long-lasting bearing
- IP44 koruma sınıfına uygun motor IP44 protection class motor
- Yüksek verimli geriye eğik kanatlı pervane High efficiency backward impeller
- Yuvarlak kanal tipi fanlar, yüksek kalite galvaniz çelik sacdan üretilmektedir Circular inline duct fans are producing from high quality galvanized sheet
- Montaj yönüne bağlı olarak aspirasyon veya ventilasyonda kullanılabilirler It can be used for both extraction and supply sides, according to route
- Dikey veya yatay monte edilebilirler It can be installed both vertical and horizontal position
- İstenildiği durumda tüm modelleri için opsiyonel, hız anahtarı ile debi kontrolü yapılabilmektedir It is suitable for speed and airflow control via controllers
- İsteğe bağlı olarak yüksek ısıya karşı termikli koruma Optionally, thermic protection can be provided

TECHNICS

	Dt 150	Dt 200	Dt 250	Dt 315
VOLTAGE (V)	230	230	230	230
FREQUENCY (Hz)	50	50	50	50
POWER (W)	85	122	145	210
CURRENT(A)	0,38	0,55	0,63	1,1
AIR FLOW (m ³ /h)	420	840	1120	1750
SPEED (rpm)	2425	2550	2635	2660
WEIGHT (kg)	4,8	5	5,5	6,9
SOUND PRESSURE LEVEL (db A) 3m	55	56	57	65

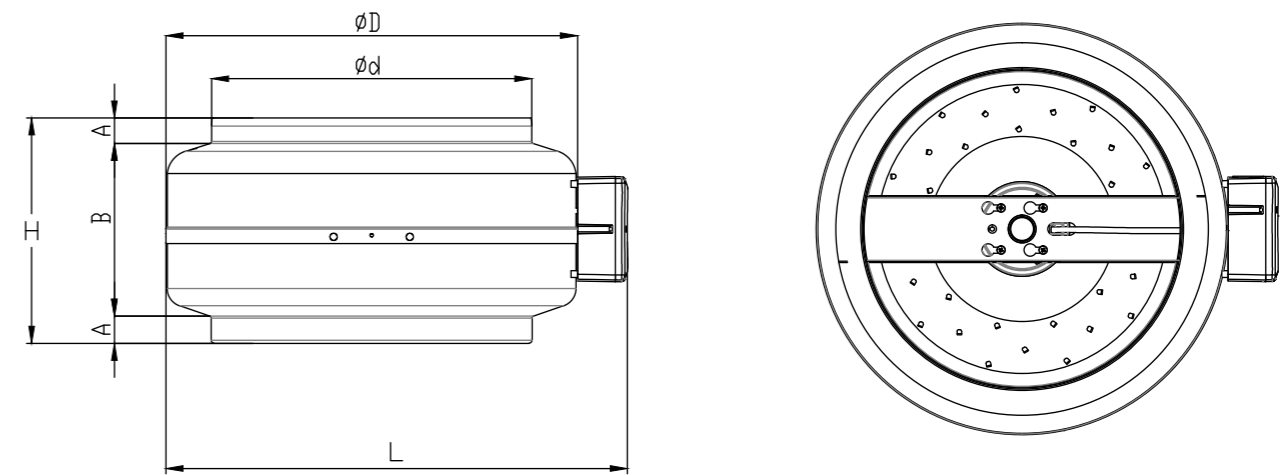

DIMENSIONS

MODEL	øD	ød	A	B	H	L
Dt-150	272	147	23	146	192	282
Dt-200	330	196	30	170	230	340
Dt-250	330	247	30	167	227	340
Dt-315		313	30	168	285	410

PERFORMANCES

MODEL	AIR FLOW (m ³ /h)				
	0 Pa	150 Pa	300 Pa	450 Pa	600 Pa
Dt 150	420	240	60		
Dt 200	840	610	320		
Dt 250	1120	900	620	300	
Dt 315	1750	1450	1060	780	300